

Application Guidelines for Invotech YM

Scroll Refrigeration Compressors

Safety Instructions

Invotech Scroll compressors are manufactured according to the latest European Safety Standards (already got the CE approvals). Safety instructions are applicable to the products below.

These instructions should be retained throughout the lifetime of the compressor. You are strongly advised to follow these safety instructions, and also the local related rules should be obeyed.

SAFETY STATEMENTS

- Refrigerant compressors must be employed only for their intended use.
- Only qualified and authorized HVAC or refrigeration personnel are permitted to install, commission and maintain this equipment.
- Electrical connections must be made by qualified electrical personnel.
- All valid standards and codes for installing, servicing, and maintaining electrical and refrigeration equipment must be observed.

ELECTRICAL SHOCK HAZARD

- Disconnect and lock out power before servicing.
- Discharge all capacitors before servicing.
- Use compressor with grounded system only.
- Molded electrical plug must be used when required.
- Refer to original equipment wiring diagrams.
- Electrical connections must be made by qualified electrical personnel.
- Failure to follow these warnings could result in serious personal injury.

PRESSURIZED SYSTEM HAZARD

- System contains refrigerant and oil under pressure.
- Remove refrigerant from both the high and low pressure side before removing compressor.
- Use appropriate back up wrenches on rotalock fittings when servicing.
- Never install a system and leave it unattended when it has no charge, a holding charge, or with the service valves closed without electrically locking out the system.
- Use only approved refrigerants and refrigeration oils.
- Personal safety equipment must be used.
- Failure to follow these warnings could result in serious personal injury.

BURN HAZARD

- Do not touch the compressor until it has cooled down.
- Ensure that materials and wiring do not touch high temperature areas of the compressor.
- Use caution when brazing system components.
- Personal safety equipment must be used.
- Failure to follow these warnings could result in serious personal injury or property damage.

Introduction

The YM Invotech Scroll™ compressor represents the latest generation of compliant scroll technology for the refrigeration industry. YM Scroll compressors are special designed for the medium temperature applications.

Nomenclature

The YM scroll model numbers include the nominal refrigeration capacity at standard 50HZ ARI rating conditions for medium temperature (-6.7/48.9°C). For additional information on this product, please refer to the online information accessible from the Invotech Scroll Technologies web site at www.invotech.cn.

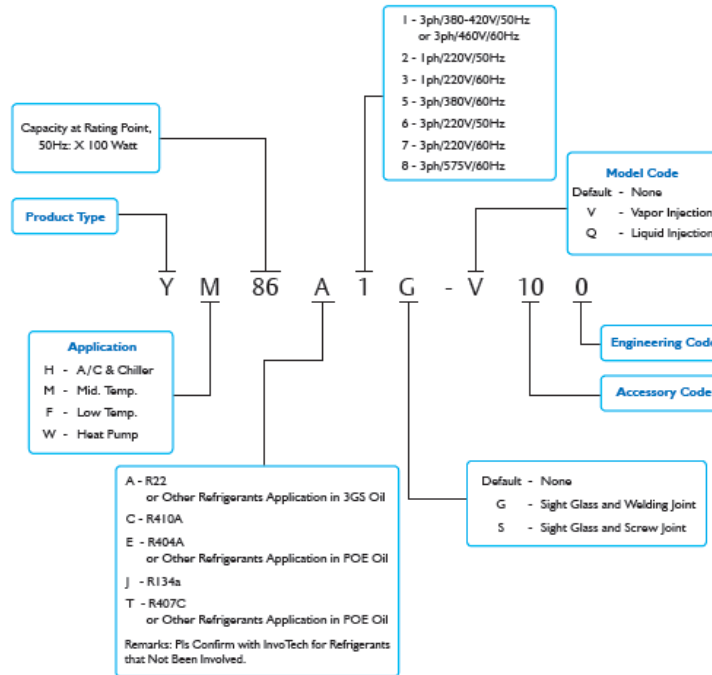

Figure 1 YM Nomenclature

Operating Envelope

The YM refrigeration scroll compressor models can be used with R22 or R404A refrigerants depending on the model selected and the lubricant used. Please check with your Invotech Application Engineer if any other refrigerants are intended to be used.

The YM**A and YM**E models are intended for medium temperature refrigeration type duty. The approved operating envelopes for these models are such that they are ideally suited for applications such as ice machines, bulk milk and cold room, etc. The models and operating envelopes are depicted in Figures 2a and 2b.

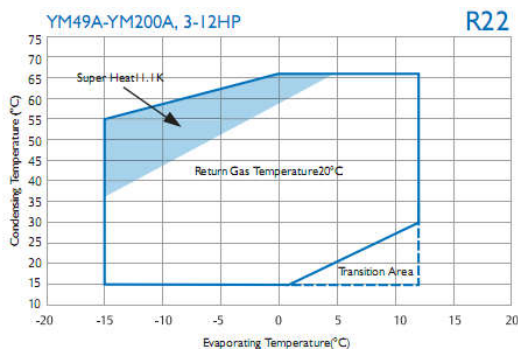

Figure 2a

YM**A Application Envelope for R22

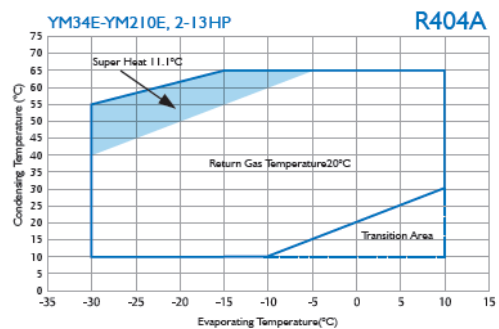

Figure 2b

YM**E Application Envelope for R404A

Accumulators

Due to the inherent ability of Invotech Scroll to handle liquid refrigerant in flooded back and defrost cycle operation conditions, accumulators may not be required. An accumulator is suggested on single compressor 2-6hp systems when the charge exceeds 4.5kg, and the single compressor 7-12hp system when the charge exceeds 8kg. On systems with defrost schemes or transient operations that allow prolonged uncontrolled liquid return to the compressor, an accumulator is required unless a suction header of sufficient volume to prevent liquid migration to the compressor is used.

Excessive liquid flood back or repeated flooded starts will dilute the oil in the compressor causing inadequate lubrication and bearing wear. Proper system design will minimize liquid flood back, thereby ensuring maximum compressor life.

In order to assure that liquid refrigerant does not return to the compressor during the running cycle, attention must be given to maintaining proper superheat at the compressor suction inlet. Invotech recommends a minimum of 8K superheat, measured on the suction line 150mm from the suction port, to prevent liquid refrigerant flood back.

Another method to determine if liquid refrigerant is returning to the compressor is to accurately measure the temperature difference between the compressor oil crankcase and the suction line. During continuous operation we recommend that this difference be a minimum of 25°C. To measure oil temperature through the compressor shell, place a thermocouple on the bottom center (not the side of the suction) of the compressor shell and insulate from the ambient.

During rapid system changes, such as defrost or ice harvest cycles, this temperature difference may drop rapidly for a short period of time. When the crankcase temperature difference falls below the recommended 25°C, our recommendation is the duration should not exceed a maximum (continuous) time period of three minutes and should not go lower than a 12°C difference.

Screens

Screens with a mesh size finer than 30 x 30(0.6mm openings) should not be used anywhere in the system with these compressors.

Crankcase Heaters

Crankcase heater is suggested to be installed on all compressors for refrigeration application.

Discharge Line Thermostat

Operation above or on the left of the operation envelope can cause high compression ratios or excessive internal compressor temperatures. This will result in overheating of the scrolls, causing excessive wear resulting in premature compressor failure.

If the system is designed where operation can't guarantee to operate inside the operation envelope, then the discharge line thermostat is required in the compressor control circuit. The suggested highest cut out setting for the discharge line thermostat is 125°C, it should be installed approximately 170mm from the discharge tube outlet, or approximately 130mm from the valve outlet port.

Pressure Controls

Both high and low-pressure switches are required on the compressors. The suggested cut out settings see table 1 below.

Control Type	R404A	R22
Low	12 PSIG min.	25 PSIG min.
High	450 PSIG max.	400 PSIG max

Table 1 high and low pressure switches setting

Pump Down Recommendations

YM models that incorporate the low-leak check valve right at the scroll discharge port; it is suitable for

pump-down applications.

For the single phase YM serials compressors, there is a small balance port on the discharge check valve to balance the high and low side inside of the compressor when the compressor is stop operating, if pump down is applied, an external check valve on the discharge line is suggested.

IPR Valve

Invotech three phase refrigeration scroll compressors have internal pressure relief valves, which open at a discharge to suction differential pressure of 380 to 440 psi. This action will trip the motor protector and remove the motor from the line. There is no IPR valve build in for the single phase compressors.

Motor Protection

Conventional inherent internal line break motor protection is provided.

Oil Types

Polyol ester lubricants must be provided for the YM**E scroll compressor is to be used with HFC refrigerants. YM**A compressors are intended for use with R22 and are supplied with mineral oil.

POE oil must be handled carefully and the proper protective equipment (gloves, eye protection, etc.) must be used when handling POE lubricant.

The system with POE oil should not be open to the air more than 15 minutes. Don't remove the suction/discharge plugs until the compressor is ready to braze.

Oil Charges

The initial oil charge is 1.4L for 2-6hp compressors, the re-charge volume is 1.25L.

The initial oil charge is 2.7L for 7-12hp compressors, the re-charge volume is 2.6L.

The initial oil charge is 3.0L for 13-15hp compressors, the re-charge volume is 2.8L.

Oil Management for Rack Applications

Invotech Scroll refrigeration compressors may be used on multiple compressor parallel rack applications. This requires the use of an oil management system to maintain proper oil level in each compressor crankcase. The sight glass connection supplied can accommodate the mounting of the oil control devices.

Unlike semi-hermetic compressors, scroll compressors do not have an oil pump with accompanying oil pressure safety controls. Therefore, an external oil level control is required.

Compressor Tubing and Mounting

Compressor mounting must be selected based on application. Consideration must be given to sound reduction and tubing reliability. Some tubing geometry or "shock loops" may be required to reduce vibration transferred from the compressor to external tubing.

Mounting for Rack Systems

Specially designed rubber grommets are available for refrigeration scroll compressor applications. These grommets are formulated from a durometer material specifically designed for refrigeration applications. The durometer limits the compressor motion, thereby minimizing potential problems of excessive tubing stress. Sufficient isolation is provided to prevent vibration from being transmitted to the mounting structure. This mounting arrangement is recommended for multiple compressor rack installations.

The standard soft grommets are not recommended for most refrigeration scroll rack installations. These softer mounts allow for excessive movement that will result in tube breakage, unless the entire system is properly designed.

Condensing Unit Mounting of Invotech YM refrigeration scroll condensing unit applications, soft mounts are recommended.

Tubing Considerations - Proper tube design must be taken into consideration when designing the tubing connecting the scroll to the remaining system. The tubing should provide enough “flexibility” to allow normal starting and stopping of the compressor without exerting excessive stress on the tube joints. In addition, it is desirable to design tubing with a natural frequency away from the normal running frequency of the compressor. Failure to do this can result in tube resonance and unacceptable tubing life. Figure 3 shows examples of acceptable tubing configurations.

The examples are intended only as guidelines to depict the need for flexibility in tube designs. In order to properly determine if a design is appropriate for a given application, samples should be tested and evaluated for stress under various conditions of use including voltage, frequency, and load fluctuations, and shipping vibration. The guidelines above may be helpful; however, testing should be performed for each system designed.

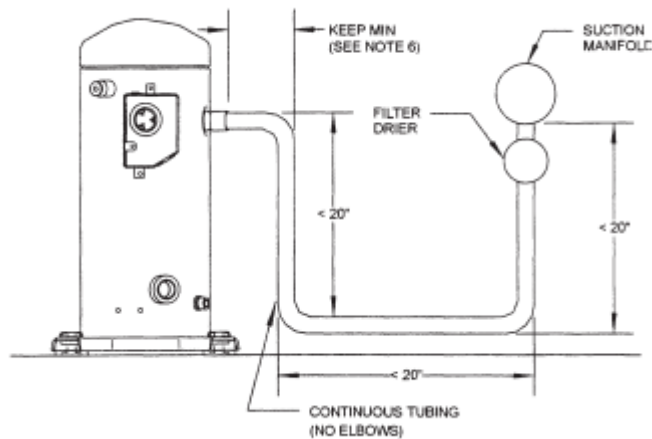

Figure 3 Typically Suction Line Arrangements

- Notes: (1) The above tubing configurations are guidelines to minimize tube stress
 (2) Follow similar guidelines for discharge tubing and oil return tubing as needed.
 (3) If a run of over 500mm is required, intermediate clamps may be necessary.
 (4) Do not hang weights on tubing (e.g. filter drier on suction tubing) except after clamps or close to the header.
 (5) Tube runs of less than 200mm is not recommended.
 (6) This dimension should be made as short as possible (e.g. 50mm or less) but still insuring a proper braze joint.
 (7) The above tubing recommendations are based on “no elbow joints”. The use of continuous tubing is preferred.

Fusite

Fusite pin orientation for single-phase and three-phase refrigeration scroll compressors are shown in Figure 4 and inside the terminal box.

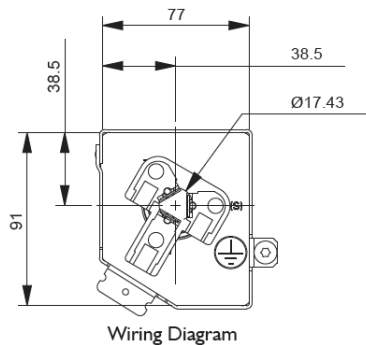

Figure 4 Motor terminal connections

Shell Temperature

System component failure may cause the top shell and discharge line to briefly reach temperatures above 150°C. Wiring or other materials, which could be damaged by these temperatures, should not come in contact with the shell.

Connection Fittings

Scroll compressors are provided with either braze connections or rota-lock adapters depending on the bill of material selected.

All YM models have copper plated steel suction and discharge fittings for a more rugged, leak resistant connection.

See section on New Installation for suggestions on how to properly braze these fittings.

Three-Phase Rotation Direction

Scroll compressors are directional dependent: i.e., they will compress in one rotational direction only. On single phase compressors, this is not an issue since they will only start and run in the proper direction (except as described in the Labeled Brief Power Interruptions). Three-phase scrolls, however, will rotate in either direction depending on the power of the phasing. So there is a 50/50 chance of connected power being “backwards.” Contractors should be warned of this. Appropriate instructions or notices should be provided by the Original Equipment Manufacturer.

Verification of proper rotation can be made by observing that the suction pressure drops and the discharge pressure rises when the compressor is energized. Additionally, if operated in reverse the compressor is noisier and its current draw is substantially reduced compared to tabulated values.

Although operation of scroll in reverse direction for brief periods of time is not harmful, continued operation could result in failure.

All three-phase compressors are wired identically internally. Once the correct phasing is determined for a specific system or installation, connecting properly phased power leads to the same fusite terminals will maintain the proper rotation.

Brief Power Interruptions

Brief power interruptions (less than 0.5 second) may result in powered reverse rotation of single-phase refrigeration scroll compressors. High-pressure discharge gas expands backward through the scrolls at power interruption causing the scroll to orbit in the reverse direction. If power is reapplied while this reversal is occurring, the compressor may continue to run noisily in the reverse direction for several minutes until the compressor internal protector trips. This has no negative effect on durability. When the protector resets, the compressor will start and run normally.

Invotech recommend the use of a timer which can sense brief power interruptions and lock the compressor out of operation for three minutes.

A three minutes time delay is also suggested on three phase models to prevent frequent start/stop.

Deep Vacuum Operation

Do not run a refrigeration scroll compressor in a vacuum. Do not run a compressor before the refrigerant charge. Failure to follow these advices can result in permanent damage to the compressor.

A low-pressure controller is required for protection against vacuum operation. See the section on pressure controls for the proper set points.

Scroll compressors (as with any refrigeration compressor) should never be used to evacuate refrigeration or air conditioning systems.

System Evacuation

An important step in effectively cleaning a system before operation is proper evacuation. Air is very detrimental to refrigeration systems and must be removed before start up and after field service. Blowing out lines with dry nitrogen may remove a major part of the air from a system, but if air is trapped in the compressor during installation it is practically impossible to remove from the compressor crankcase by purging with nitrogen.

New compressors are shipped with a dry air holding charge, and must be evacuated before being put in the system.

Triple evacuation of the system or compressor, as required, is strongly recommended (twice to 1500 microns and finally to 500 microns), breaking the vacuum each time with 30 PSIG dry nitrogen. The vacuum pump must be connected to both the high and low sides of the system through properly sized coactions, since restrictive service connections may make the process so slow as to be unacceptable, or may lead to false readings because of pressure drop through the fittings.

Charging Process

Do not power on the compressor before charging refrigerant.

Use the scale to control charge quantity. One liquid drier is recommended to connect between refrigerant cylinder and manifold to prevent moisture into system during charging. Connect refrigerant cylinder to both high and low side of the refrigeration system, power on the solenoid valve if possible (do not power on the compressor at this time). Invert refrigerant cylinder if needed to ensure only liquid can be charged into both high and low sides. Charge the refrigerant to the system as much as needed (at least 70% of total needed). Disconnect the high side charge port, turn on the compressor, and continue charge the liquid from the low side until the refrigerant is enough for the system.

Never close the suction service valve when compressor is running.

Unbrazing System Components

If the refrigerant charge is removed from a scroll unit by bleeding the high side only, it is sometimes possible for the scrolls to seal, preventing pressure equalization through the compressor. This may leave the low side shell and suction line tubing pressurized. If a brazing torch is then applied to the low side, the pressurized refrigerant and oil mixture could ignite as it escapes and contacts the brazing flame. It is important to check both the high and low sides with manifold gauges before un-brazing. In the case of an assembly line repair, remove the refrigerant from both the high and low sides. Instructions should be provided in appropriate product literatures and assembly areas.

High Potential (Hi-pot) Testing

Invotech scroll compressors are configured with the motor below the compressor. As a result when liquid refrigerant is within the compressor shell the motor can be immersed in liquid refrigerant to a greater extent than with compressors with the motor mounted above the compressor. When compressors are Hi-pot tested and liquid refrigerant is in the shell, they can show higher levels of leakage current than compressors with the motor on top because of the higher electrical conductivity of liquid refrigerant than refrigerant vapor and oil. This phenomenon can occur with any compressor when the motor is immersed in refrigerant. The level of current leakage does not present any safety issue. To lower the current leakage reading the system should be operated for a brief period of time to redistribute the refrigerant to a more normal configuration and the system Hi-pot tested again. Under no circumstances should the Hi-pot or Meg-ohm test be performed while the compressor is under a vacuum.

Invotech Scroll Functional Check

Refrigeration scroll compressors do not have internal suction valves. It is not necessary to perform functional compressor tests to check how low the compressor will pull suction pressure. This type of test may damage a scroll compressor. The following diagnostic procedure should be used to evaluate whether an Invotech Scroll compressor is functioning properly.

1. Verify proper unit voltage.
2. Normal motor winding continuity and short to ground checks will determine if the inherent overload motor protector has opened or if an internal short to ground has developed. If the protector has opened, the compressor must cool sufficiently to reset.
3. With service gauges connected to suction and discharge pressure fittings, turn on the compressor. If suction pressure falls below normal levels, the system is either low on charge or there is a flow blockage.
- 4a. Single-Phase Compressors
If the suction pressure does not drop and the discharge pressure does not raise to normal levels the compressor is faulty.
- 4b. Three-Phase Compressors

If the suction pressure does not drop and the discharge pressure does not rise, reverse any two of the compressor power leads and reapply power to make sure the compressor was not wired to run in the reverse direction.

The compressor current draw must be compared to published compressor performance curves at the compressor operating conditions (pressures and voltages). Significant deviations ($\pm 20\%$) from published values may indicate a faulty compressor.

New Installation

- The copper-coated steel suction, discharge, and injection tubes on scroll compressors can be brazed in approximately the same manner as any copper tube.
- Recommended brazing material - Any Silfos material is recommended, preferably with a minimum of 5% silver. However, 0% silver is acceptable.
- Use of a dry nitrogen purge to eliminate possibility of carbon buildup on internal tube surfaces is recommended. Wet rag is recommended to use to avoid the overheating of the painting and other parts not requiring brazing.
- Be sure process tube fitting I.D. and process tube O.D. are clean prior to assembly.
- Remove the discharge plug at first, then remove the suction plug.
- Apply heat in copper tube. As tube approaches brazing temperature, move torch flame to the joint.
- Heat the joint area until braze temperature is attained, moving torch up and down and rotating around tube as necessary to heat tube evenly. Add braze material to the joint while moving torch around circumference.
- After braze material flows around joint, move torch to heat fitting. This will draw the braze material down into the joint. The time spent heating Area 3 should be minimal.
- As with any brazed joint, overheating may be detrimental to the final result.

Field Service To Disconnect:

- Recover refrigerant from both the high and low side of the system. Cut tubing near compressor. Check the high and low pressure with pressure gauge to make sure no pressure inside the system.

To reconnect:

- Recommended brazing materials - Silfos with minimum 5% silver or silver braze material with flux.
- Reinsert tubing fitting.
- Heat tube uniformly in Area of copper tube, moving slowly to the joint area. When joint reaches brazing temperature, apply brazing material.
- Heat joint uniformly around the circumference to flow braze material completely around the joint.
- Slowly move torch in fitting to draw braze material into the joint.
- Do not overheat joint.